

Product Information

FISTOPWATCHIN-D - Solar Stopwatch Insert

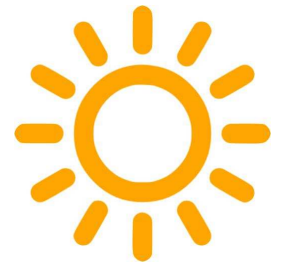

Ensure the Stopwatch's solar panel is installed facing the sun's position at midday.

Locate away from trees, buildings or any structure which may cast a shadow over the solar panel

Designed to British & European Standard BS EN 1176

Insert Supplied Pre-assembled

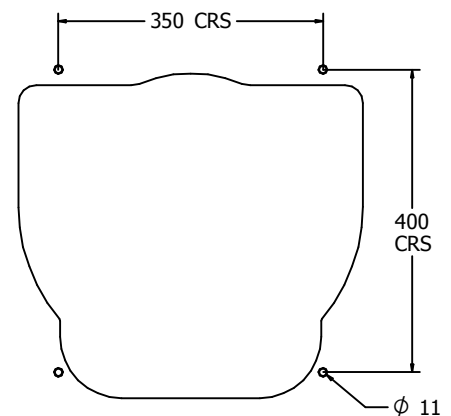

Cutout required in host panel

Age Range: 2+ Years
Largest Part: 495 x 585 x 57mm
Heaviest Part: Approx. 7Kg
Total Weight: Approx. 7Kg
Surfacing : N/A

Minimum Inspection Schedule	
Inspection Type	Inspection Frequency
Visual	Every Month
Functionality	Every Month
Comprehensive	Every 6 Months

Material: **Design Panel** - High Density Polyethylene (HDPE) with orange peel texture finish

Colour Choices: **Design Panel** - Broad selection available, visit the website below for further details